

# Instructions Manual

omegon



***Omegon® N114/900 EQ-1***

English version 9.2016 Rev A Art. Nr 11266

## The Omegon® N 114/900 EQ-1

*Congratulations on the purchase of the new Omegon® N 114/900 EQ-1. This telescope will give you hours of fun, with its all optical mirror lens and light gathering capability; it is the ideal companion to start in the world of amateur astronomy. With this telescope, you will be able to see the craters on the Moon, star clusters, some nebulae, the Jupite'sr disc features and its Galilean moons and the rings of Saturn.*

**Included parts.** Besides the complete telescope, we have also included the following accessories: ***Eyepiece K25mm, Eyepiece K10mm, Barlow lens 2x, Finderscope;***

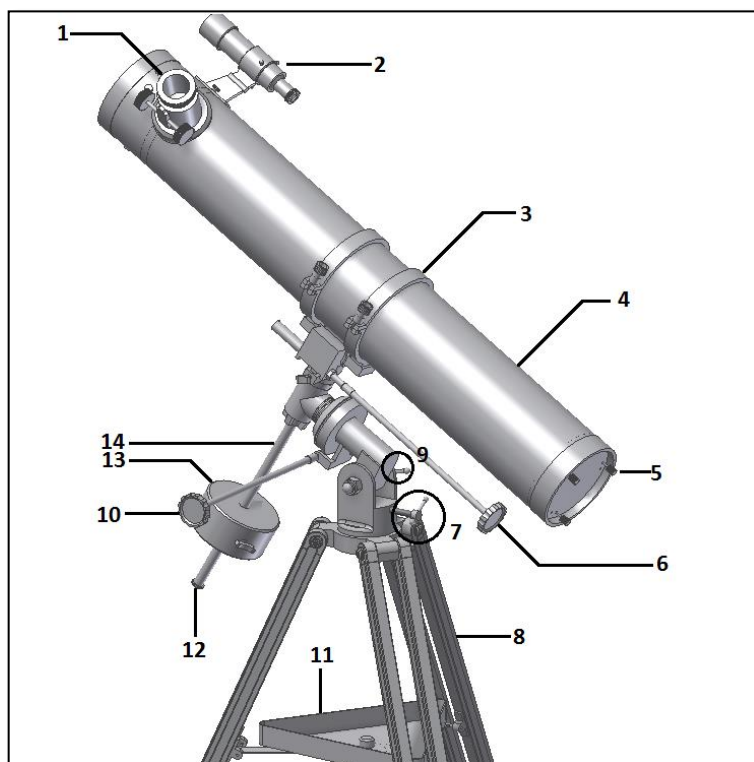

Figure 1. Parts description.

### 1. Knowing your telescope.

- |   |  |
|---|--|
| 1- Focuser;                                   | 8- Tripod leg;                               |
| 2- Finderscope;                               | 9- Altitude side fix knob (partially shown); |
| 3- Tube ring;                                 | 10- R.A. adjustment handle;                  |
| 4- Optical tube;                              | 11- Accessory tray;                          |
| 5- Collimation thumbscrew for primary mirror; | 12- Counterweight stop/foot saver;           |
| 6- Declination adjustment handle;             | 13- Counterweight;                           |
| 7- Altitude/Latitude adjustment;              | 14- Counterweight shaft;                     |

**2. Getting Started.** It is very simple to get started. Here is how the telescope works. The telescope should point to the object being observed. The mirror at the bottom of the telescope's tube gathers the object's light and reflects it to the secondary mirror that brings it to the eyepiece. Close to the telescope's aperture, there is the focuser. The focuser tube moves up and down to get a precise focused image. At the focuser, one can use the supplied accessories. Different accessories combinations give different results, such as different image magnifications or correct image. But all this will be explained in detail in the next pages. **3. Assembly.** Start by setting up the tripod as shown in figure 2. Use the supplied bolts and nuts. Next, place the accessory tray (part #11 – fig. 1) and fix it using the wing nuts and small screws – fig. 3. After this, the tripod should be stable. Place the equatorial mount head on top of the tripods base, as shown in figure 4. Use the supplied hand-bolt to fix it. Thread the counter-weight shaft and slide the counter-weight (figure 5). Use the counter-weight's thumbscrew to avoid it from slipping. Place the control-handles as shown in figure 6. Now fix the tube's ring (figure 7) and place the tube. The mount's altitude axis can be adjusted as shown in figure 8. Use the side hand-knob to tighten or release the altitude's axis (fig. 9). Release the R.A. locking thumbscrew so that the R.A. axis is loose. Slide the counter-weight's position to balance the axis (figure 10). Proceed likewise with the Dec. Axis; slide the tube (figure 11).



Figure 2. Tripod assembly.



Figure 3. Tray placement.



Figure 4. Place equatorial head on top of tripod.

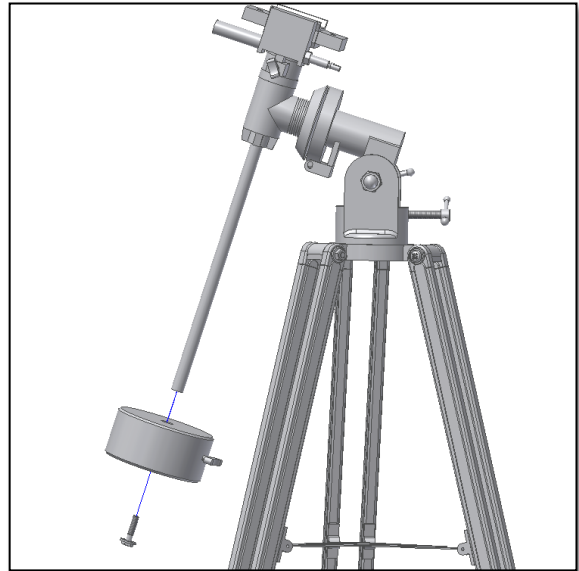

Figure 5. Thread the counter-weight shaft. Insert counterweight.



Figure 6. Fix Dec. and R.A. handles.

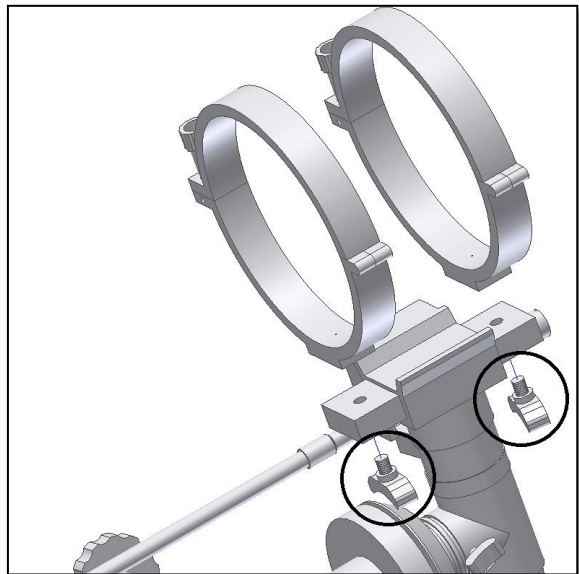

Figure 7. Fix the tube's ring.

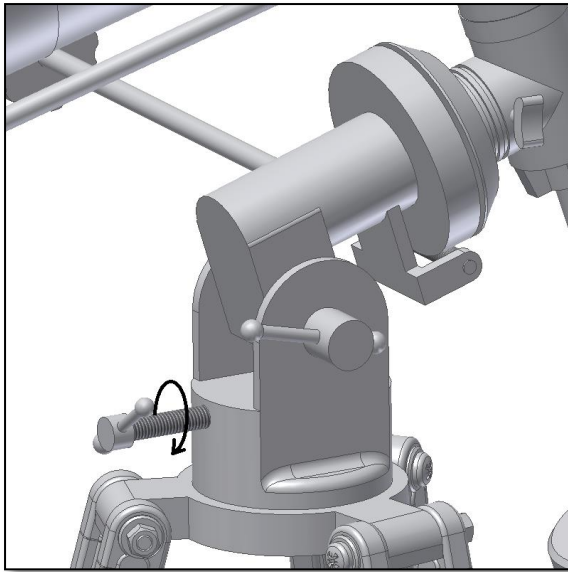

Figure 8. Adjust Dec. axis.

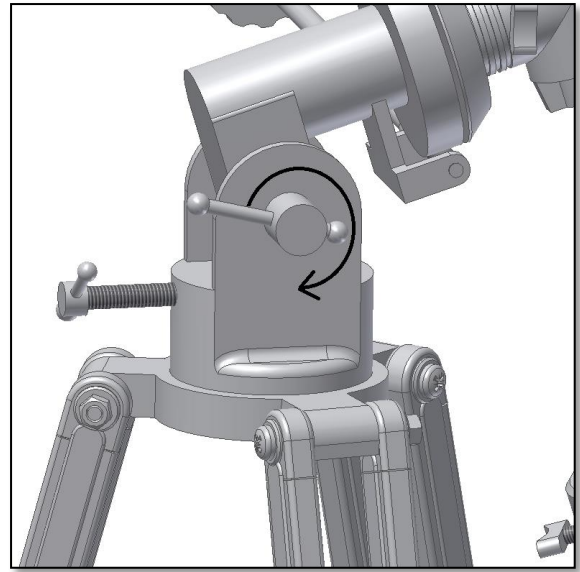

Figure 9. Tighten the side hand-knob.

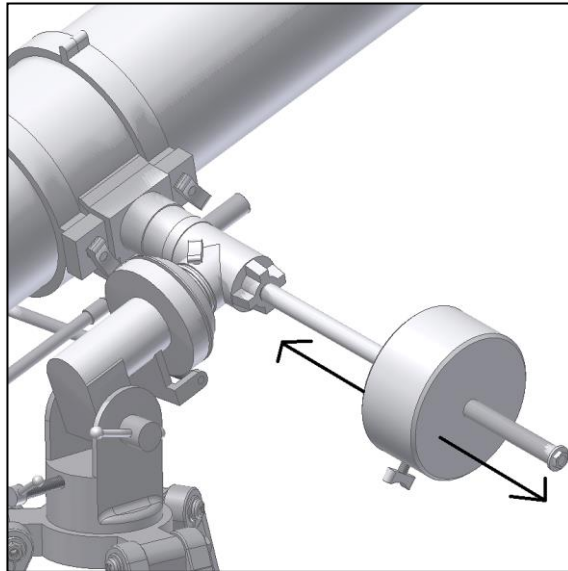

Figure 10. Balance the R.A. axis with counterweight.

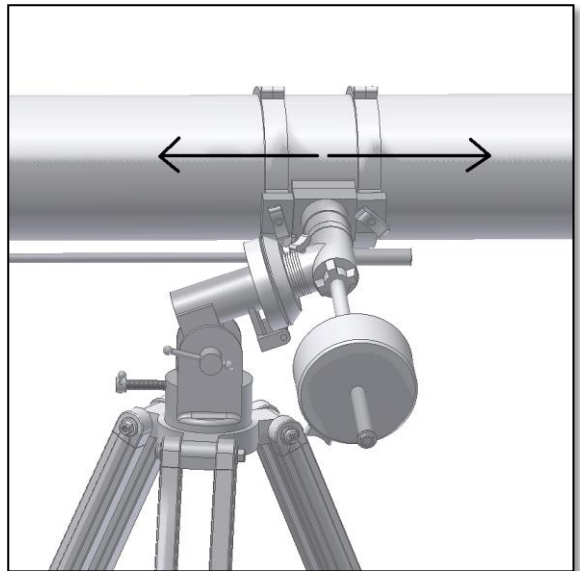

Figure 11. Balance the Dec. axis.

#### 4. How to use the equatorial mount.

The equatorial mount is a powerful tool for astronomical observation. The main purpose of an equatorial mount is to accurately point a telescope to a certain object. There are two axis in the equatorial mount. A R.A. axis and a Dec. axis. The telescope's tube sits on the Dec axis.

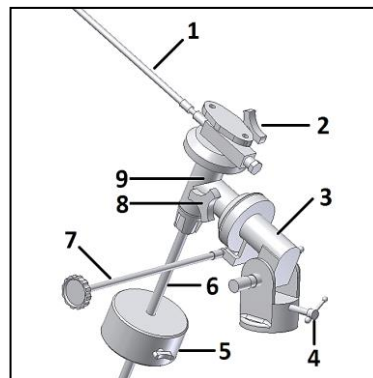

Figure 12. Detailed mount parts.

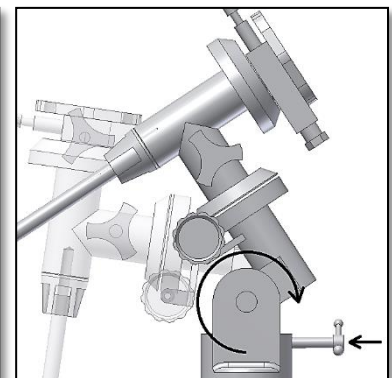

Figure 13. Adjusting latitude/altitude.

#### Equatorial mount parts description

1- Declination Handle

4- Latitude/altitude adjustment

7- R.A. Handle

2- Declination Fixing Knob

5- Counterweight

8- R.A. Fixing Knob

3- R.A. Axis

6- Counterweight shaft

9- Dec. Axis

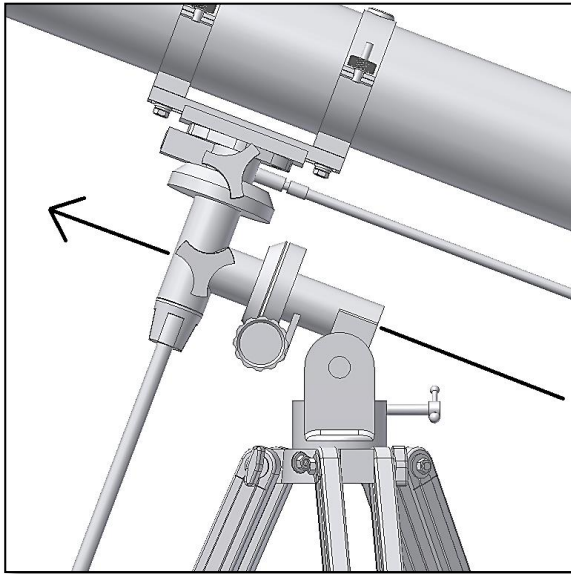

Figure 14. R.A. Axis.

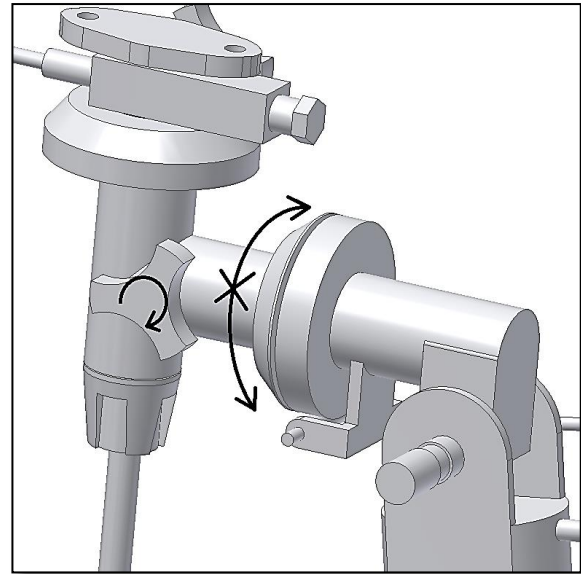

Figure 15. Locking the R.A. axis.

There are two axis in the eq. mount. One is the **R.A. (Right Ascension) axis** as shown in fig. 14. This means the telescope can rotate around this axis. The R.A. should point north to Polaris. Tracking (see what this is below) is made using the R.A. axis. To lock the rotation the locking R.A. knob should be used (fig. 15). The second axis is the **Dec (Declination) axis** – fig. 16. To lock this axis use the Dec locking knob as shown in figure 17.

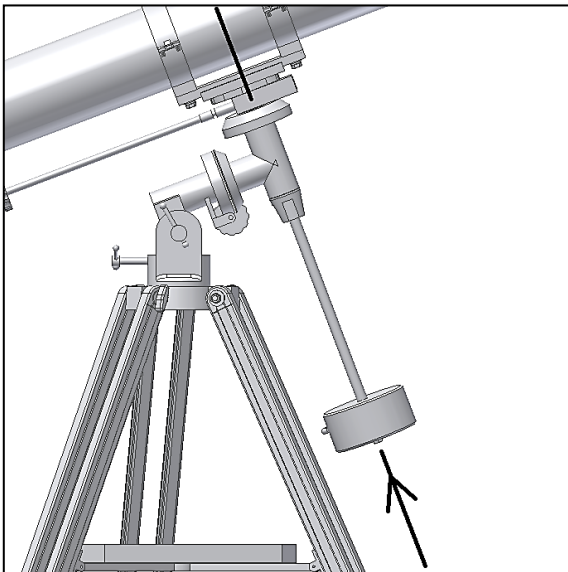

Figure 16. Dec. Axis.

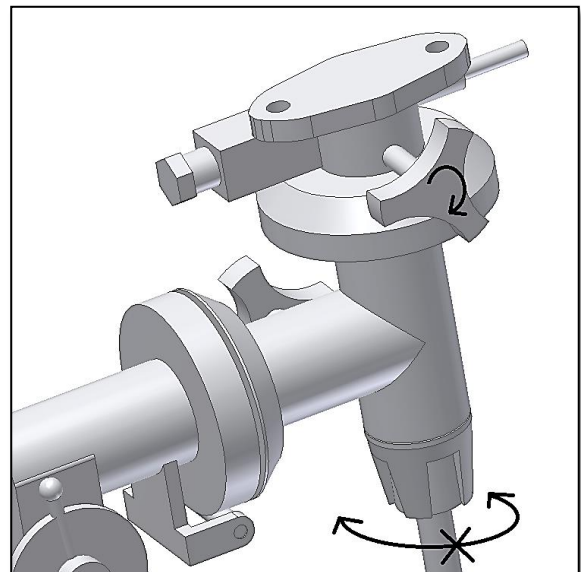

Figure 17. Locking the Dec. Axis.

#### 4.1. What is tracking?

Star's positions rotate, slowly but surely, in the night sky. This is caused by the Earth's rotation. Every 24 hours the Earth make a complete turn. So does the night sky. This means that, when observing through a telescope, the stars will move away from the field of view after a few seconds. This is even more evident when using high power eyepieces. They go away quite easily from the field of view.

**Use the Dec and R.A. handles to precise point the telescope. Make sure the axis are securely locked.**

To keep a star in the centre of the field of view tracking is required. *Tracking can be done manually or by a motor.* Manual tracking can be done using the tow Dec and R.A. handles. They allow small

corrections to be made in each axis. However this is not the recommend procedure to track an object. The mount should be placed in station i.e. aligned in such a way that only the R.A. is required to turn to track a star. **4.2. How to set the mount in station.** Point the telescope's R.A. axis to

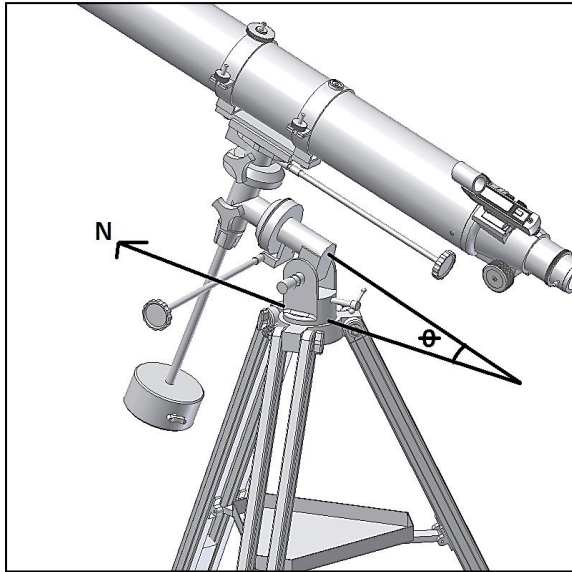

Figure 18. Mount points north.

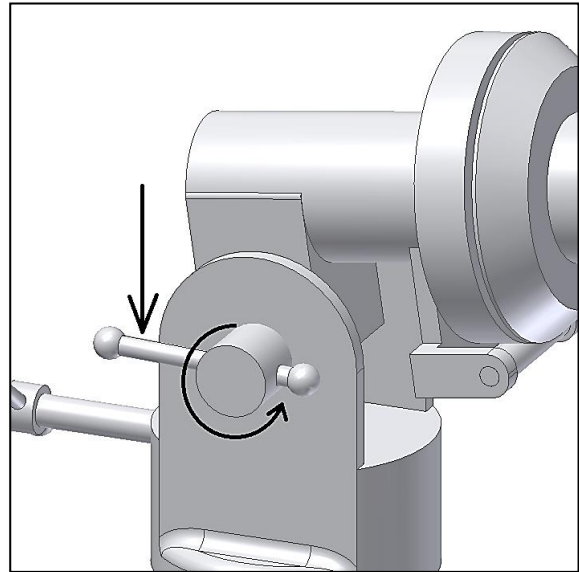

Figure 19. Release altitude break and adjust inclination.

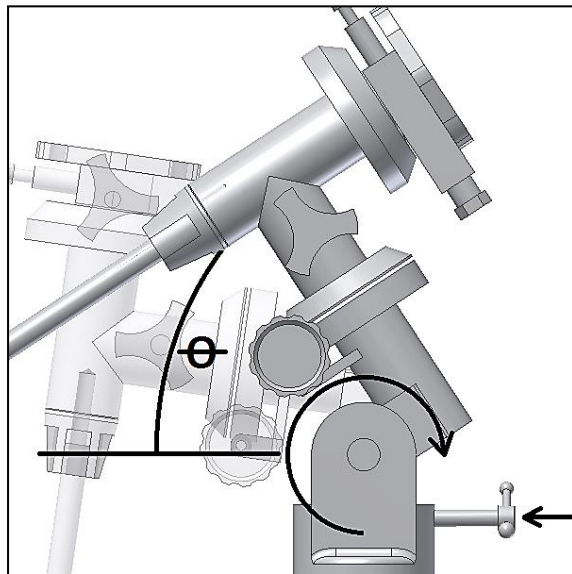

Figure 20. Adjust inclination to latitude.

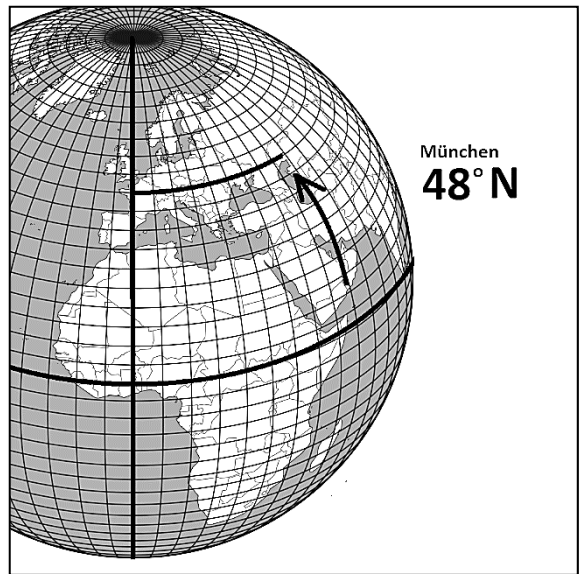
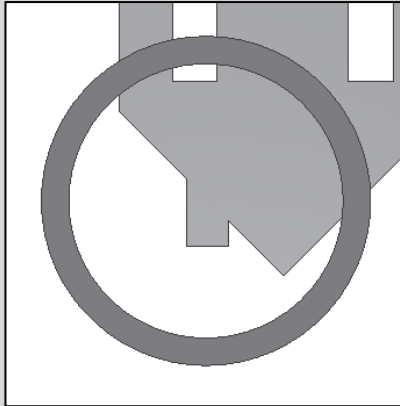

Figure 21. Check your latitude.

north – fig. 18. Release the altitude break - fig. 19- so that the R.A. inclination can be adjusted. Rotate the latitude adjustment so that the inclination of the mount is the same as the latitude of observers. For an observer in Munich the latitude is 48 degrees. The inclination angle ( $\Theta$ ) should be approximately 48 degrees. Make sure to re-tighten the altitude break. Now that the mount is pointing north and has the observer's location latitude your mount is set on station. This mean that the mount should not be moved during observation. The two R.A. and Dec. axis can be used to position and point the telescope to any part of the sky.

**The altitude/latitude adjustment should NOT be used when observing. Continuous use can cause wear or even break the knob.**

## 5. Aligning the Finderscope



**Figure A.** A distant object is centered at the telescope's field of view. In this example we have a house with a chimney. The chimney is the reference point to place at the center of the field of view. We first look through the telescope with the lowest magnification possible (H20mm should be preferable). So we have the widest field of view.

### STEP 1



**Figure B.** Looking through the finderscope we see the same building but in this case the chimney is not centered. We adjust the finderscope using the three thumbscrews so that the finderscope moves slightly. This is enough to correct the objects position in the finderscope. Trial and error is required to get a satisfactory result. Make sure to tighten the 3 screws after finishing so that the finderscope tube does not move.

### STEP 2

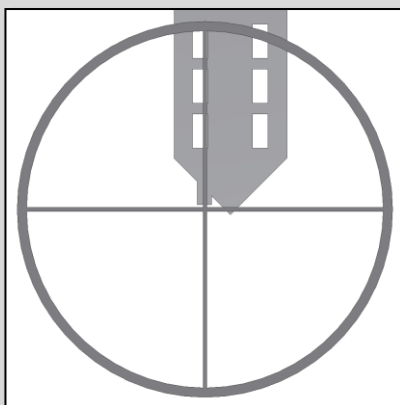

**Figure C.** After playing with the three finderscope thumbscrews and some trial and error we get the finderscope rectangle close to the center (in this case the chimney). The Finderscope is now ready to use!

### STEP 3

## 6. Alignment of the optics and collimation.

Telescopes require periodical checking for the alignment of the optics. The optics should be aligned (or collimated) so that the telescope can achieve a good performance and deliver a

sharp image. This is especially important for reflector telescopes (that use mirrors). First let's start by checking collimation.

Look for a bright star in the evening sky and centre it in the eyepiece field of view. Some power is required to check alignment, make sure the star is focused. Now use the focuser knobs and rotate so that the star comes out of focus (defocused). You will be able to see a defocused star. It will appear as a series of rings. These are called diffraction rings and they will be important to determine how good (or how bad is the alignment – figure 23). If the optics are well aligned you will be able to see a defocused star similar to a series of concentric rings (1 in figure 23), a poorly aligned telescopes will show a series of eccentric rings (2 in figure 23).

The telescope is equipped with a set of collimation screws for both the secondary mirror (figure 25) and for the primary mirror (figure 26). They can be used to adjust the tilt of both mirrors and to achieve alignment. This information is for your reference.

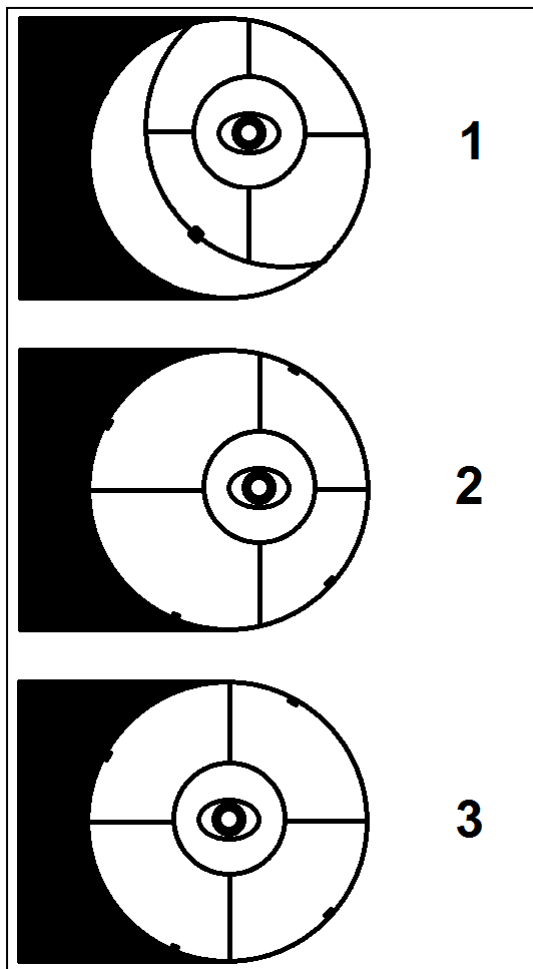

Figure 22. Different stages of collimation.

## 6. Collimate the optics.

Remove the eyepiece from the telescope's focuser. If look directly to the secondary mirror will see a reflection of your eye. The light is being reflected from the secondary mirror to the primary and back.

Figure 22 shows the different stages of collimation.

1- Telescope optics completely out of collimation. Adjustment is necessary both in the secondary as in the primary mirror.

2- Secondary mirror is aligned but primary mirror needs adjustments.

3- Telescope's optics are aligned and star test should show concentric rings. The telescope will perform at its best.

### 6.1. So how to get to good alignment?

6.1.1. Let's start with the secondary mirror. Peeking at the focuser without the eyepiece and looking at the secondary mirror one can see the reflected eye. One can also see the telescope secondary spider vanes (4 vanes cross shaped) and the primary mirror's holding pads (figure 24).



The secondary mirror can be adjusted by using the 3 screws (figure 25). Releasing it can make the secondary mirror support to rotate. So make sure you only adjust a screw at a time to avoid it. The secondary mirror should always show up as a circle and not an ellipse. Please make sure this is the case.

As soon as you get the primary mirror and the primary mirror pads centred (figure 22 – 2) you are good to go to the next step.

6.1.2. The primary mirror needs to be adjusted. Adjusting the primary mirror will move the secondary mirror reflection to the centre. Use the 6 screws on the back of the telescope. Notice that 3 screws are used to adjust the tilt of the primary mirror while the three others are used to hold the tilt position. Adjust the primary mirror so that you get all reflections centred (figure 22 – 3). Your telescope is now collimated. Check the diffraction rings (figure 23) and repeat it necessary.

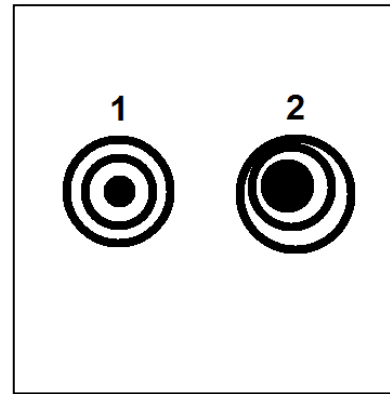

Figure 23. Diffraction Rings: 1. good alignment and 2. Poorly aligned

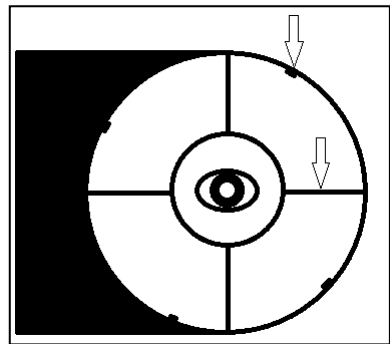

Figure 24. Vanes and primary pads.

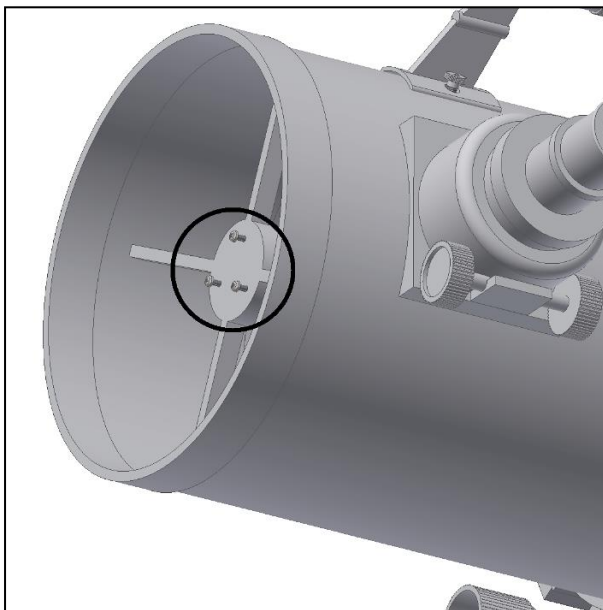

Figure 25. Secondary mirror adjustment screws.

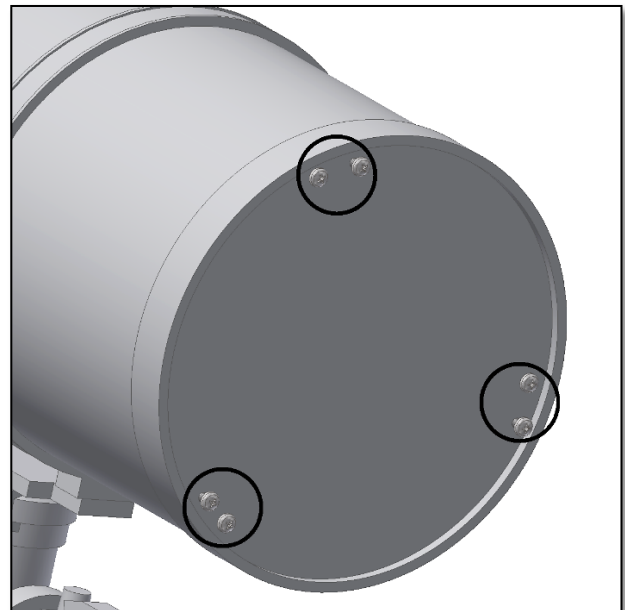

Figure 26. Primary mirror adjustment screws.

**ATTENTION! Never look at the Sun through a telescope. Concentrated Sun light may cause serious eye injury. Children should use only with adult supervision!**

## 7. What can be seen with this telescope?

Below you will find some examples of what you can expect to see when using this telescope.



**7.1.** The Moon is one of the most spectacular objects to be seen through a telescope. Even a small telescope will reveal high detail of the Moon's surface. You will be able to see the craters on the Moon's surface and other features like the Mare. The moon is a very bright object. It is better to observe it when the Moon is not full. Try the crescent Moon and look for features along the terminator (between illuminated and dark surfaces).



**7.2.** Jupiter is the biggest planet of our solar system. It is also one of the favorite targets for beginners. Galileo was able to discover that the four tiny dots that turn around the planet were in fact part of Jupiter's system of moons. With this telescope you will not only be able to see Jupiter's planet disc with its two major discernible bands, but also its biggest moons, Io, Europa, Ganymedes and Callisto.



**7.3.** The "lord of the rings" of the night skies, Saturn is by far the most popular target for small telescopes. Saturn's rings are discernible even at 60x magnification. In a very good night you will be able to see the Cassini's division (the darker band on the Saturn's rings).

**8. Using the accessories, a bit of math to understand how all it works.**

Using the accessories is easy and fun. To change magnification simply swap eyepieces. To get more magnification simply use the barlow lens. But how does all of this work?

**8.1. Power (magnification)**

Your telescope has a focal length of 900mm. This is approximately the distance between the telescope lens and its focal point (very similar to the distance between the focus point of a loupe and the loupe lens). This is a very important feature, that allows to determine several interesting facts such as magnification. The magnification is determined by the telescope's focal length and the used eyepiece. You probably noticed that the two supplied eyepieces are K25mm and K10mm. This means that the K25mm is a 25mm focal length eyepiece while the K10mm is a 10mm focal length eyepiece. To determine the magnification just divide the telescope's focal length by the eyepiece's focal length. Let's give an example for our telescope and the supplied eyepieces:  
Telescope's focal length is 900mm.  
K25mm eyepiece's focal length is 25mm.

$$\frac{900mm}{25mm} = 36 \text{ power}$$

This means that the K25mm eyepiece provides a 36x power (magnification). This seems low, but when you try it, you will see a bright image with some (very good) details.

**8.2. Barlow Lens**

The barlow lens is a very interesting device. It is a negative lens, that multiplies the telescope's focal length. So a 2x Barlow multiplies the original focal length by 2x, in this case  $900mm \times 2 = 1800mm$ . A 3x Barlow lens multiplies by 3x. Your telescope is supplied with a 2x Barlow lens. When used with the H20mm eyepiece you get 2x the power obtained before

$$36 \text{ power} \times 2x \text{ Barlow} = 72 \text{ power}$$

**8.3. Erecting lens (not included)**

The erecting lens gets you an upright image view with the telescope. It also adds some power like the barlow lens. The Erecting Lens provides an extra 1.5x power.

**Some possible accessory combinations**

	Terrestrial View	Moon	Deep Sky	Jupiter and Saturn
Barlow Lens 2x				Yes
K25mm Eyepiece			Yes	
K10mm Eyepiece		Yes		Yes
Power	<i>Does not apply</i>	90x	36x	180x